

An aerial photograph showing a large area of land affected by a fire. The ground is a mix of dark, charred earth and lighter, brownish-grey ash. A thick, vibrant blue plume of smoke or steam rises from the right side of the image, partially obscuring the ground below. The overall scene is dramatic and somber.

**ONE
CLAPHAM
JUNCTION** LONDON

THE
ASCENT

INTRODUCTION PAGE 02

LOCATION PAGE 06

THE DEVELOPMENT PAGE 26

APARTMENTS PAGE 38

MOUNT ANVIL AND PEABODY PAGE 72

A short  **CYCLE**
from *the River*, 
ONE MINUTE from
the  **STATION**,
ONE CLAPHAM JUNCTION
^{ISA}
→ *destination* that
TRANSPRTS YOU

KENSINGTON 24 MINS CYCLE

RIVER THAMES 14 MINS WALK

BATTERSEA PARK 10 MINS CYCLE

SOHO 35 MINS CYCLE

CHELSEA 12 MINS CYCLE

↗ WESTMINSTER 23 MINS CYCLE

→ VAUXHALL 19 MINS CYCLE

→ THE CITY 32 MINS CYCLE

**CLAPHAM JUNCTION
STATION** ➔ Ⓜ 01 MIN WALK

- Imperial Wharf 04 MINS
- London Victoria 06 MINS
- London Waterloo 08 MINS
- Gatwick Airport 24 MINS

**ONE
CLAPHAM
JUNCTION** LONDON

Bring EVERYTHING closer

A fresh, leafy stop  on SW11's colourful journey, each of **ONE CLAPHAM JUNCTION'S** distinctive apartments echoes the golden age of **TRANSPORTATION**. Every detail is intrinsically Clapham, like subtle nods to the area's history in its amenities and **PELTON HUB**. ONE MINUTE from one of London's **BEST-CONNECTED** stations,  **ONE CLAPHAM JUNCTION BRINGS EVERYTHING CLOSER** 

A TOWN ↓
within a CITY

A VILLAGE
within a → TOWN

With its diverse creative community and storied heritage, Clapham ⁰¹ epitomises the London village. It's hardly surprising that it's so sought after among buyers and renters.

Clapham bridges two worlds – the lush, **BOLD OPEN SPACES** of some of London's most-loved commons, and the buzz of London's favourite **BOUTIQUES** and **BARS**. And with **CHELSEA** and **FULHAM** just the other side of Battersea Bridge, your world only widens.

Whatever your speed, Clapham Junction never stands still for long.

01



01



02



03



01 **LIFE OF FISH** 12 MINS TAXI

A local favourite offering fresh sustainable fish from the coast and high quality deli-style produce.

TRINITY 07 MINS TAXI

For some of the best seasonal dishes in the city, treat yourself to a meal at Trinity. It's traditional, it's classy and it's Michelin starred.

02, 04 **MINNOW** 08 MINS TAXI

On sunny days you can enjoy the outside seating whilst catching up with friends. The laid back approach means you can enjoy the seasonal menu at your leisure.

03 **BAYLEY & SAGE** 09 MINS WALK

Few things in life compare with the joy of finding a good deli – and Bayley & Sage is one of the best. Fill your cupboards with the best deli food in SW11.

04



05



SINABRO 09 MINS WALK

If you're after something a little more casual, wander down to Sinabro for some of the best French food in London. Ask for the tasting menu.

LITTLE BIRD 11 MINS WALK

For a fun night out, try Little Bird – an extremely Instagrammable cocktail bar serving superb Asian fusion dishes. Quirky doesn't begin to cover it.

AUX MERVEILLEUX DE FRED 08 MINS WALK

If you couldn't tell by the long queue at the door, this bakery makes some of the best croissants and pastries in London.

05 JOICE 09 MINS TAXI

Coffee and a cannoli, or a delicious home-cooked lunch, this coffee spot offers it all.

PEAR TREE CAFE 07 MINS TAXI

Sunny afternoons are best spent in the common, and The Pear Tree Cafe, with its outdoor seating and atmospheric lighting, is the perfect place to enjoy their delicious all-day menu.

VENN STREET MARKET 10 MINS TAXI

Every Saturday, vendors flood Venn Street with stalls from street food and fresh fruit to crafts and flowers.

06 HONEST BURGER 10 MINS TAXI

Delicious homemade burgers that never disappoint.

07 BERBERÈ PIZZERIA 10 MINS TAXI

Clapham or Calibria – authentic sourdough pizzeria run by Italian brothers Mateo and Salvorde. We promise you won't regret having one to yourself.

06



07





08

PHILGLAS & SWIGGOT 07 MINS WALK

Expand your palate at the locals' favourite independent wine merchant.

11 NORTHCOTE ROAD ANTIQUES MARKET 07 MINS TAXI

Find the perfect curio to really tie your living room together.

08 MOEN AND SONS 08 MINS TAXI

Long established butchers, offering a variety of well-sourced produce to choose from.

ARCHER STREET 07 MINS TAXI

Combining high-energy West End performers with premium drinks, Archer Street has the feel of a ritzy member's bar – minus the membership fees.

CLAPHAM PICTURE HOUSE 11 MINS TAXI

Want to see the latest blockbuster or prefer a classic, this charming independent cinema offers it all.

09 NORTHCOTE GALLERY 11 MINS WALK

Take in some modern British and International contemporary paintings and sculpture at Northcote Gallery.

10 THE WINDMILL 11 MINS TAXI

With its spectacular views of Clapham Common – not to mention London's most famous resident pub dog – there's no place quite like The Windmill.

09



10



11



Local HIGHLIGHTS

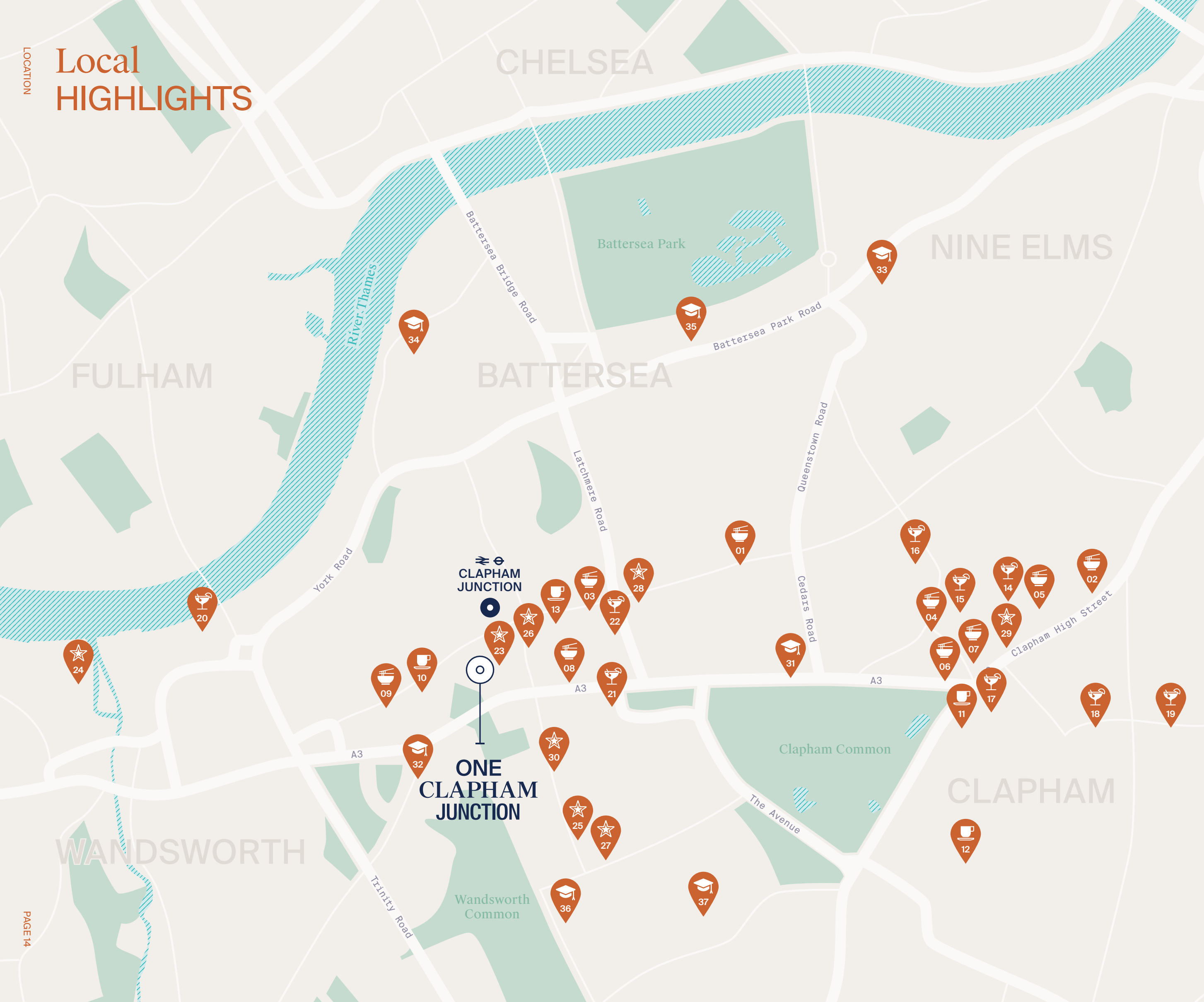

RESTAURANTS

- 01 Pizzeria Pellone 15 MINS WALK
- 02 Tsunami 11 MINS TAXI
- 03 Mien Tay 06 MINS WALK
- 04 Trinity 08 MINS TAXI
- 05 Sorella 09 MINS TAXI
- 06 Minnow 08 MINS TAXI
- 07 Mamalan 09 MINS TAXI
- 08 Sinabro 08 MINS WALK
- 09 Kaosarn 08 MINS WALK



CAFÉS

- 10 Story Coffee 06 MINS WALK
- 11 'The Black Lab' Coffee House 10 MINS TAXI
- 12 Bistro Union 12 MINS TAXI
- 13 Jacks at the Junction 03 MINS WALK



PUBS and BARS

- 14 The Stonhouse 10 MINS TAXI
- 15 The Sun 08 MINS TAXI
- 16 The Bobbin 07 MINS TAXI
- 17 The Alexandra 10 MINS TAXI
- 18 Coach & Horses 12 MINS TAXI
- 19 Hope & Anchor 13 MINS TAXI
- 20 The Ship 06 MINS TAXI
- 21 Little Bird 10 MINS WALK
- 22 Four Thieves 06 MINS WALK



LIFESTYLE

- 23 Clapham Grand 01 MIN WALK
- 24 The Avenue Cookery School 11 MINS TAXI
- 25 Pottery Café 13 MINS WALK
- 26 12 Rounds Boxing Gym 01 MIN WALK
- 27 Northcote Road Antiques Market 13 MINS WALK
- 28 Battersea Arts Centre 08 MINS WALK
- 29 Clapham Picturehouse 10 MINS WALK
- 30 Northcote Road Market 09 MINS WALK



EDUCATION

- 31 Eaton House The Manor School 06 MINS TAXI
- 32 Emanuel School 12 MINS WALK
- 33 Newton Preparatory School 10 MINS TAXI
- 34 Thomas's Battersea 06 MINS WALK
- 35 The Dominic 08 MINS TAXI
- 36 Northcote Lodge 07 MINS TAXI
- 37 BroomWood Hall School 07 MINS TAXI

★ BRING 

EVER  *TH*  *ING*

 CLOSER

01



Walk a few minutes in any direction
 → and you'll stumble across Clapham's
UNIQUE and ★ **LIVELY**
 neighbouring districts.

02



The independent boutiques and cafés
 of St. John's Hill, Northcote Road ⁰¹ and
 its fashionable foodie haunts.



The diverse amalgamation of pubs, bars and
 restaurants nestled around Clapham Old Town
 and Battersea Rise. Or, for a change of pace,
 try the laid back buzz of Lavender Hill.

The BUCOLIC BLISS of South London

One Clapham Junction lets its flora and fauna take centre stage. Its trees and wildflower gardens evoke a serene, breezy mood that's perfect for young families... and beyond its gates, the expansive parks of South West London await.

The perfect blend of wild and tame, Clapham ⁰² and Wandsworth Commons ⁰¹ are dotted with ponds, tennis courts, cafés, cricket nets and plenty of green, open space.



02



A place for LEARNING

Imperial College
London



KING'S
College
LONDON

UNIVERSITY OF
WESTMINSTER



ual: london college
of communication



For students, Clapham sits on London's doorstep,
with Clapham Junction train station putting universities
across the capital within easy reach.

PRIMARY SCHOOLS

The Dominie School 08 MINS TAXI

Eaton House 06 MINS TAXI

Newton Preparatory School 10 MINS TAXI

⁰¹ Thomas's Battersea 6 MINS TAXI

SECONDARY SCHOOLS

Emanuel School 12 MINS WALK

UNIVERSITIES (BY PUBLIC TRANSPORT)

University of Westminster 22 MINS

London South Bank 25 MINS

King's College London 25 MINS

University College London (UCL) 25 MINS

London College of
Communication (UAL) 26 MINS

London School of Economics (LSE) 27 MINS

Imperial College London 27 MINS

01



View our education guide in full by scanning the QR code

The WORLD at YOUR door

Heading further afield? Easy. With one of London's best-connected stations on your doorstep, you can be in the city, at the airport, the countryside or the beach in no time.

From Clapham North station, the Northern Line offers its wide array of connections, or catch an Uber boat for a more nautical jaunt into the city.

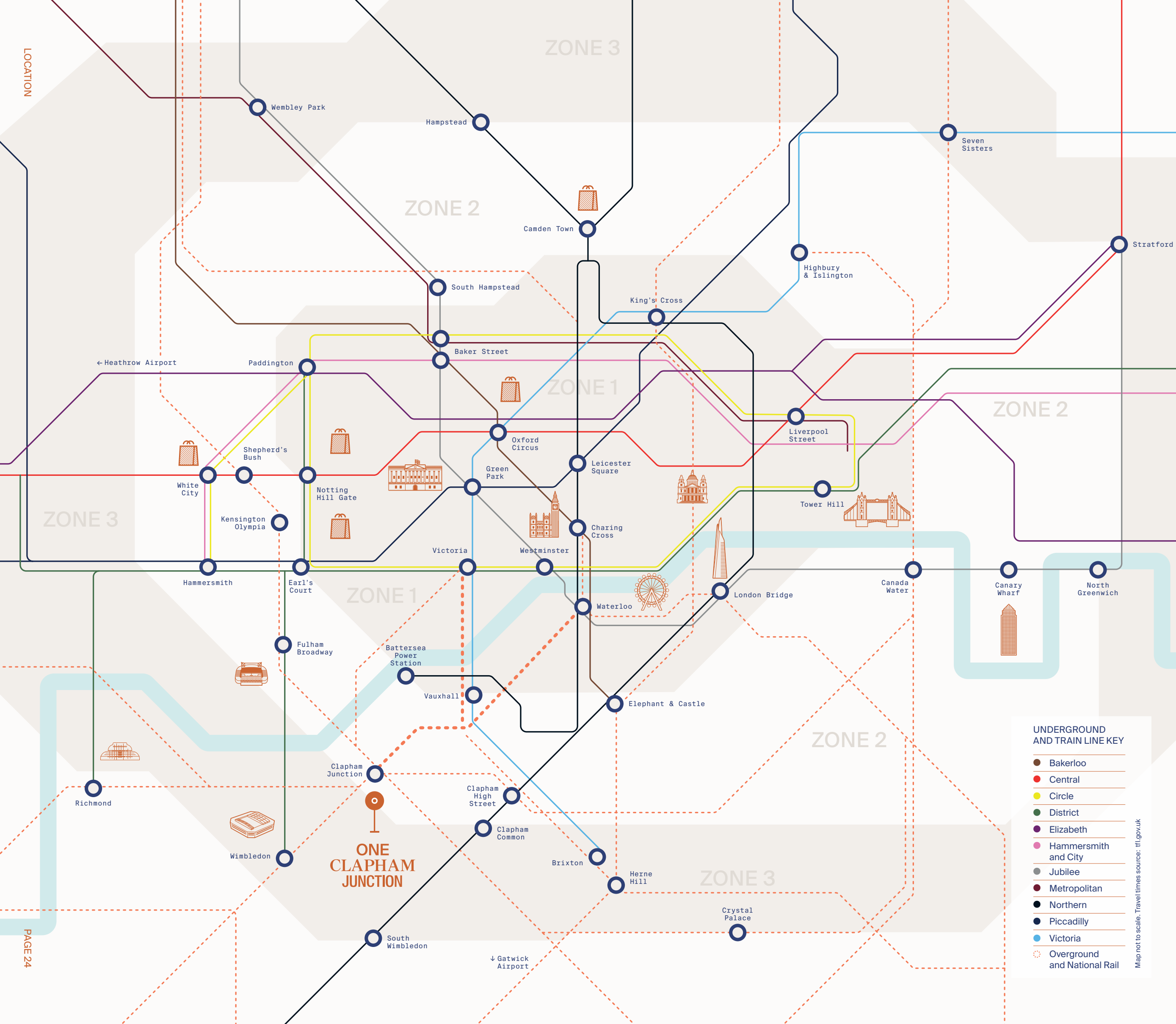

DESTINATION BY TRAIN FROM CLAPHAM JUNCTION

Vauxhall 04 MINS

Victoria 06 MINS

Wimbledon 07 MINS

Waterloo 08 MINS

Richmond 08 MINS

Gatwick Airport 24 MINS

Windsor & Eton Riverside 45 MINS

Heathrow Airport 41 MINS

Brighton 60 MINS

The LONG and WINDING railroad

One Clapham Junction wears its history on its sleeve. And what a history it's been. As Clapham itself has transformed into a diverse, vibrant community, so too has the development. Opening up to the surrounding area and inviting in the unique energy, community and landscape of Clapham Junction.





- 01 THE ASCENT 3C/3D
- 02 THE ARRIVAL 3A/3B
- 03 THE APPROACH 7/8
- 04 THE SQUARE
- 05 MONARCH SQUARE
- 06 CLAPHAM JUNCTION STATION  1 MIN WALK

Today, as part of an AWARD-WINNING development, One Clapham Junction comprises 307 HOMES across SIX distinctive buildings.



Tipping its hat to the area's history, each building's distinctive brickwork patterns are linked to the architectural landmarks that have stood close by, for many years.

From the hard-working forms of the Edwardian Eckstein Road terraces, to the diamond motifs and colours of St Mark's Church and Ark John Archer School in Wandsworth.

Past meets PRESENT

THE SQUARE ⁰¹

Through the artwork gate, The Square is a space for socialising, shaded and sun-dappled by resplendent poplars and plane trees. Throughout the year, The Square plays host to myriad seasonal pop-ups including community events, performances and garden markets.

SWALE GARDENS

With the pastoral serenity of native trees and sunken gardens, the whimsical paths and social benches of Swale Gardens immerse you in some of the most relaxing outdoor space in South West London.

FLORAL PASSAGE

This natural passage connects visitors with the diverse resident wildlife – complete with bug hotel – sheltering in the development.



THE COURTYARD

Private moments? Playful gatherings?
With its sun deck and south-facing social
lawn, The Courtyard caters for both – a natural
setting for both the young and old alike.

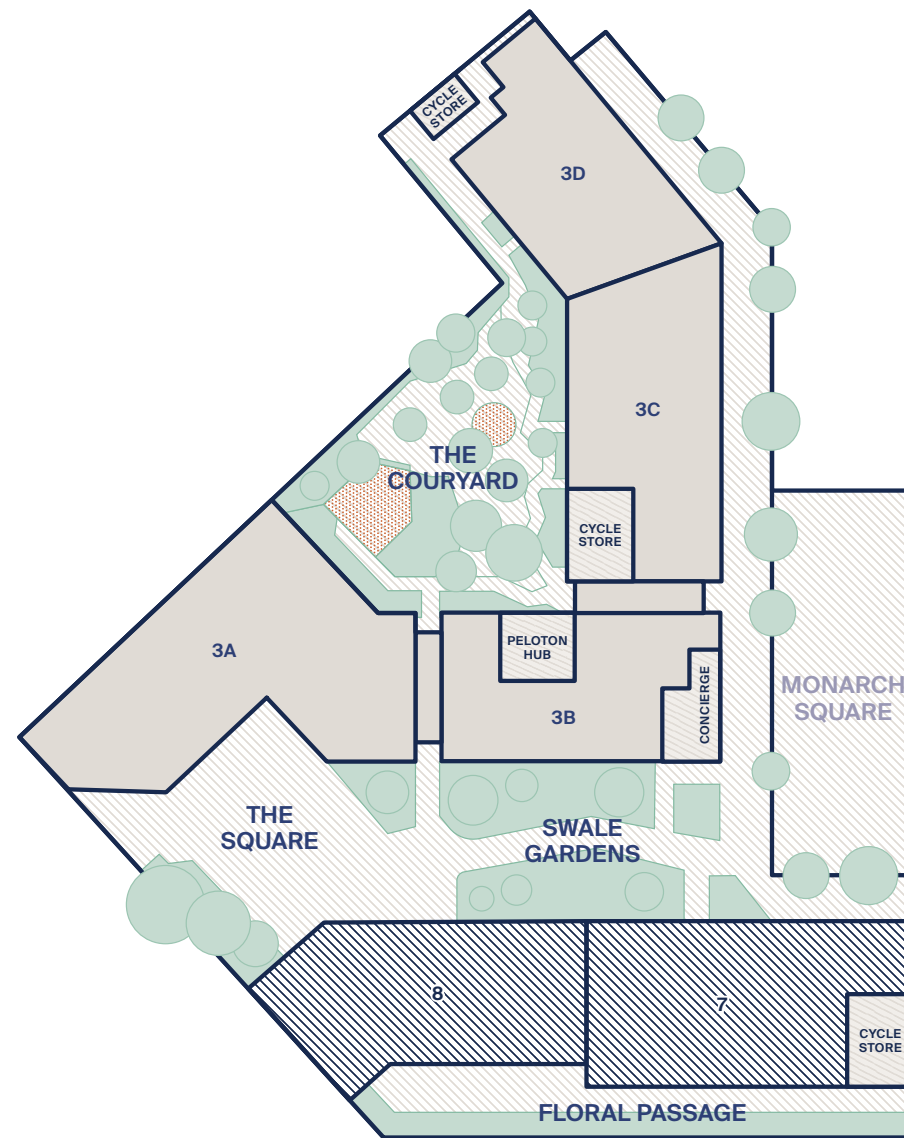

Tucked away from the busyness of Clapham
High Street, the climbing fauna of The
Courtyard's walls cycle through the rich colours
of each season, and a quiet woodland trail
leads through an other-worldly pine canopy.

SURPRISE and DELIGHT

Throughout the gardens, you'll find
quiet spots, for a **VILLAGE-LIKE
COMMUNITY**. In the charming
Swale  Gardens, **ONE CLAPHAM
JUNCTION** offers something priceless
— **SPACE** just to relax.

01



CONCIERGE ^{01,02}

First impressions are important. We've made it one to remember, with 24-hour concierge service to welcome you home each day.

02



03



PELOTON HUB ⁰³

Forget bulky equipment clogging up your living areas. Forget run-down equipment in dreary shared gyms. Whether you're charging up or winding down, the Peloton Hub puts wellbeing at the centre of One Clapham Junction life.

It's a dedicated space to plug in, tune out and zone in on your goals.



Welcome IN

In every room, **COMFORT**
and **CRAFT** in equal measure.
It's the small touches. The burnished
bronze ironmongery and black fittings.
The chrome hardware offers a chic,
modern nod to its **INDUSTRIAL**
PAST. But it's more than aesthetic.
IT'S BUILT TO LAST.





↑ **BEDROOM** MASTER BEDROOM

- 01 TIMBER EFFECT DOORS
- 02 ENERGY EFFICIENT DOWNLIGHTS
- 03 HALF-MOON FEATURE HANDLES

→ **EN-SUITE SHOWER** 2/3 BED

- 01 TERRAZZO EFFECT PORCELAIN TILES
- 02 CURVED FRAME WALL MIRROR
- 03 BLACK SLIDING SHOWER SCREEN



→ LIVING/DINING 2 BED

- ⁰¹ NATURAL WASHED OAK EFFECT
PARQUET FLOORING
- ⁰² GLAZED DOOR ONTO BALCONY





↓ KITCHEN 1 BED

- 01 HANDLELESS DOOR DESIGN
- 02 LOW-LEVEL AND TALL CABINTRY IN FOREST GREEN FINISH
- 03 BLACK FINISH SOCKETS WITH USB CHARGING POINT



← BATHROOM 2/3 BED

- 01 WHITE MARBLE EFFECT PORCELAIN
- 02 FOREST GREEN METRO WALL TILES
- 03 MONOCHROME GEOMETRIC PORCELAIN TILES

↓ BALCONY VIEW TOWARDS THE COURTYARD

- 01 DECKING TO BALCONIES
- 02 GLAZED DOOR ONTO BALCONY



01



↑ LIVING ROOM 1 BED

- 01 NATURAL WASHED OAK EFFECT PARQUET FLOORING
- 02 ENERGY EFFICIENT DOWNLIGHTS
- 03 GLAZED DOOR ONTO BALCONY





↑ BATHROOM 1 BED

- 01 CURVED FRAME WALL MIRROR
 02 GLASS SHELVING
 03 LARGE FORMAT TERRAZZO-EFFECT PORCELAIN FLOOR AND WALL TILES

SPECIFICATION

INTERIOR finishes

- Entrance door with bronze finish ironmongery
- White painted internal doors with linear groove profile and bronze finish handles
- White painted square edge skirtings and architraves
- Natural / grey washed oak, luxury wood-effect parquet flooring to kitchen, living and dining areas (Incl. studio open-plan bedrooms)
- Full-height built-in wardrobes to master bedroom, with grey and timber effect doors and half-moon feature handles
- Internally painted, with shelving and black finish hanging rails
- Carpet to bedrooms
- Painted walls and ceilings finished in white matt emulsion

KITCHENS (Design features/cabinetry)

- Individually designed layouts
- Marble effect, solid surface worktop with off-white hues
- Vertical metro tiled splashback in glazed off white finish
- Feature slim shaker wall cabinets in natural oak-effect finish
- Low-level / tall cabinetry in forest green finish
- Handle-less door design
- Concealed, under wall cabinet LED strip lighting
- Black finish sockets with USB charging point

APPLIANCES

- Studio and One-bedroom apartments**
- Single lever mixer-tap in stylish brushed black finish
 - Single bowl, inset sink in black finish
 - Siemens 4-ring touch control induction hob, black ceramic finish
 - Siemens integrated combination microwave / oven
 - Siemens integrated fixed canopy extractor
 - Siemens integrated 70/30 fridge-freezer
 - Integrated slimline dishwasher
 - Washer/dryer located in utility cupboard

- Two & Three-bedroom apartments**
- Single lever mixer-tap in stylish brushed black finish
 - 1 ½ bowl sink in black finish
 - Siemens black integrated multi-function single oven
 - Siemens black integrated microwave
 - Siemens integrated fixed canopy extractor
 - Siemens integrated 70/30 fridge-freezer
 - Integrated dishwasher
 - Washer/dryer located in utility cupboard
 - Siemens 4-ring touch control induction hob, black glass finish

BATHROOM and SHOWER rooms

- Studio/Shower room/ One-bedroom Bathroom**
- Large format terrazzo-effect porcelain floor and wall tiles
 - Blue vertical metro wall tiles above vanity height
 - Bespoke, feature vanity with semi recessed basin, integrated storage and solid surface countertop
 - Curved frame wall mirror, glass shelving and wall mounted shaver socket
 - Feature wall-mounted, cross head tap design in brushed bronze finish
 - Dual flush wall-mounted WC pan with soft close seat
 - Brushed bronze, ceiling mounted shower head and wall mounted shower handset
 - Brushed bronze, wall-mounted temperature/diverter control
 - Brushed bronze, electric heated towel bar
 - White single-ended acrylic bath brushed bronze bath filler. (Studios have low profile shower tray only)
 - Black finish, two panel bath/shower screen (Studios include frameless fixed glass shower screen with black wall fixing)

Bathroom – Two & Three-bedroom

- Large format white marble-effect porcelain, low level wall tiles
- Forest green vertical metro wall tiles above vanity height
- Monochrome diagonal stripe porcelain floor tiles
- Bespoke, feature vanity with semi recessed basin, integrated storage and solid surface countertop
- Curved frame wall mirror, glass shelving and wall mounted shaver socket
- Feature wall-mounted, cross head tap design in chrome finish
- Dual flush wall-mounted WC pan with soft close seat
- Chrome finish, ceiling mounted shower head and wall mounted shower handset
- Chrome finish, wall-mounted temperature/diverter control
- Black finish, electric heated towel bar
- White single-ended acrylic bath brushed bronze bath filler
- Black finish, two panel bath/shower screen

Shower room –Two & Three-bedroom

- Large format Terrazzo-effect porcelain floor tile
- Large format light grey porcelain low level wall tile
- Blue vertical metro wall tiles above vanity height
- Bespoke, feature vanity with semi recessed basin, integrated storage and solid surface countertop
- Curved frame wall mirror, glass shelving and wall mounted shaver socket
- Feature wall-mounted, cross head tap design in chrome finish
- Dual flush wall-mounted WC pan with soft close seat

- Chrome finish, ceiling mounted shower head and wall mounted shower handset Chrome finish, wall-mounted temperature/diverter control
- Black finish, electric heated towel bar
- Low profile, white finish shower tray
- Sliding door glass shower screen with black frame

ELECTRICAL fittings

- Energy efficient LED ceiling downlighters
- Lighting to utilities where applicable
- Black finish switches and sockets throughout
- USB charging point to living room, kitchen and master bedroom
- Data points to master bedroom
- High speed broadband available (subject to connection)

Studio apartments

- Television and satellite points to living area

One, Two & Three-bedroom apartments

- Television and satellite points to bedrooms and living areas

HEATING and COOLING

- Heating, hot water and power from central system with metered water/ electric supply
- Independently zoned, thermostatically controlled underfloor heating throughout
- Whole-House ventilation
- Comfort cooling to selected rooms in selected apartments. Refer to your sales consultant

BALCONIES

- Glazed door onto balconies and terraces
- Non-combustible decking to balconies

RESIDENT amenities

- 24-hour concierge
- Peloton hub
- Landscaped garden and public realm
- Car parking: secure underground parking spaces, available by separate negotiation
- Cycling storage provision to all apartments

Entrance LOBBIES, LIFTS and HALLWAYS

- Interior designed concierge, entrance lobbies and hallways
- Bespoke desk within concierge, feature lighting and reception lobby
- Carpet floor finishes, painted walls to upper levels communal corridors
- Two passenger lifts located within each entrance lobby serving floor levels

SUSTAINABLE features

- Mixed recycling facilities
- Landscaping to encourage biodiversity
- Provision for electric vehicle charging points (EVCP)
- Roof top solar panels

SECURITY and peace of mind

- Audio/Visual entry system
- Mains supply heat and smoke detectors and fitted with battery back-up, domestic fire sprinkler system
- Multi-point locking and spy hole to apartment entrance doors
- 24-hour monitored CCTV
- Access control to car parks, bicycle storage, main entrance lobby and Peloton hub
- 999-year lease
- Two-year fixtures and fittings warranty
- 10-year warranty

MANAGEMENT company

- A management company will be appointed to administer the effective operation and maintenance of communal facilities for which a service charge will be levied and apportioned to the benefit offered.



THE ASCENT GROUND Level



3C.00.01 2 BED	TOTAL AREA	102.7 sq m	1105 sq ft
	Kitchen	2.70 x 2.45m	8'10" x 8'0"
	Living/Dining	4.60 x 4.86m	15'1" x 15'11"
	Master Bedroom	3.15 x 6.40m	10'4" x 21'0"
	Bedroom 2	5.95 x 3.12m	19'6" x 10'3"
	Internal Area	86.7 sq m	933 sq ft
	Terrace	10.70 x 1.5m	35'1" x 4'11"
	External Area	16.05 sq m	173 sq ft

3C.00.02 1 BED	TOTAL AREA	66.8 sq m	719 sq ft
	Kitchen	2.35 x 3.00m	7'9" x 9'10"
	Living/Dining	3.05 x 7.44m	10'0" x 24'5"
	Bedroom	3.13 x 4.80m	10'3" x 15'9"
	Internal Area	57.9 sq m	623 sq ft
	Terrace	6.36 x 1.40m	20'11" x 4'7"
	External Area	8.91 sq m	96 sq ft

3C.00.03 2 BED	TOTAL AREA	84.3 sq m	907 sq ft
	Kitchen/Dining	4.96 x 2.45m	16'3" x 8'0"
	Living	3.64 x 4.58m	11'11" x 15'0"
	Master Bedroom	3.25 x 4.70m	10'8" x 15'5"
	Bedroom 2	2.74 x 4.74m	9'0" x 15'7"
	Internal Area	70.2 sq m	756 sq ft
	Terrace	9.75 x 1.44m	32'0" x 4'9"
	External Area	14.08 sq m	152 sq ft

3C.00.04 2 BED	TOTAL AREA	88.86 sq m	957 sq ft
	Kitchen/Dining	4.68 x 3.00m	15'4" x 9'10"
	Living	4.17 x 3.97m	13'8" x 13'1"
	Master Bedroom	3.28 x 4.63m	10'9" x 15'2"
	Bedroom 2	2.86 x 5.44m	9'4" x 17'10"
	Internal Area	74.4 sq m	801 sq ft
	Terrace	10.30 x 1.40m	33'10" x 4'7"
	External Area	14.42 sq m	155 sq ft

3D.00.01 1 BED	TOTAL AREA	63.72 sq m	686 sq ft
	Kitchen	3.73 x 4.25m	12'3" x 13'11"
	Living/Dining	3.78 x 2.97m	12'5" x 9'9"
	Bedroom	3.25 x 4.93m	10'8" x 16'2"
	Internal Area	53.1 sq m	571 sq ft
	Terrace	7.31 x 1.45m	24'0" x 4'9"
	External Area	10.65 sq m	115 sq ft

3D.00.02 2 BED	TOTAL AREA	85.11 sq m	916 sq ft
	Kitchen/Living/Dining	4.83 x 5.16m	15'10" x 16'11"
	Master Bedroom	3.77 x 3.60m	12'5" x 11'10"
	Bedroom 2	3.44 x 3.23m	11'4" x 10'7"
	Internal Area	73.1 sq m	787 sq ft
	Terrace	8.97 x 1.34m	29'5" x 4'5"
	External Area	12.02 sq m	129 sq ft

3D.00.03 1 BED	TOTAL AREA	61.61 sq m	663 sq ft
	Kitchen	3.94 x 3.10m	12'11" x 10'2"
	Living/Dining	3.99 x 3.79m	13'1" x 12'5"
	Bedroom	3.25 x 4.75m	10'8" x 15'7"
	Internal Area	51 sq m	549 sq ft
	Terrace	7.92 x 1.34m	26'0" x 4'5"
	External Area	10.61 sq m	114 sq ft

3D.00.04 STUDIO	TOTAL AREA	51.73 sq m	557 sq ft
	Kitchen	1.73 x 2.78m	5'8" x 9'1"
	Living/Dining	4.71 x 3.04m	15'5" x 10'0"
	Bedroom	2.75 x 3.03m	9'0" x 10'0"
	Internal Area	42.1 sq m	453 sq ft
	Terrace	6.97 x 1.39m	22'10" x 4'7"
	External Area	9.65 sq m	104 sq ft

3D.00.05 STUDIO	TOTAL AREA	51.39 sq m	553 sq ft
	Kitchen	3.40 x 1.84m	11'2" x 6'0"
	Living/Dining	2.54 x 5.58m	8'4" x 18'4"
	Bedroom	2.50 x 4.86m	8'2" x 15'11"
	Internal Area	45.6 sq m	491 sq ft
	Terrace	4.02 x 1.43m	13'3" x 4'9"
	External Area	5.79 sq m	62 sq ft



GROUND LEVEL

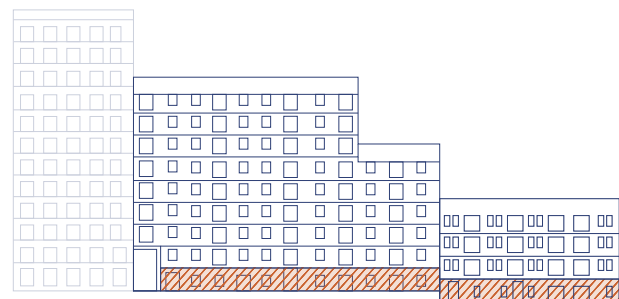

SITE MAP

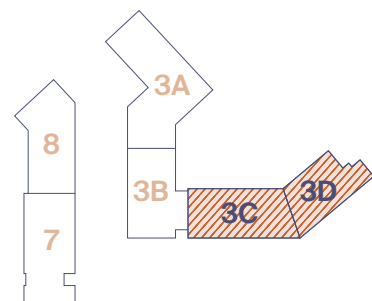

THE ASCENT Level 01



3C.01.01 2 BED	TOTAL AREA Kitchen Living/Dining Master Bedroom Bedroom 2 Internal Area Balcony External Area	93.7 sq m 2.70 x 2.45m 4.60 x 4.86m 3.15 x 6.40m 5.95 x 3.12m 86.7 sq m 4.15 x 1.71m 70.8 sq m	1009 sq ft 8'10" x 8'0" 15'1" x 15'11" 10'4" x 21'0" 19'6" x 10'3" 933 sq ft 13'7" x 5'7" 76 sq ft
--------------------------	---	--	--

3C.01.02 1 BED	TOTAL AREA Kitchen Living/Dining Bedroom Internal Area Balcony External Area	63.3 sq m 2.35 x 3.00m 3.05 x 7.44m 3.13 x 4.80m 57.9 sq m 2.95 x 1.82m 5.37 sq m	681 sq ft 7'9" x 9'10" 10'0" x 24'5" 10'3" x 15'9" 623 sq ft 9'8" x 6'0" 58 sq ft
--------------------------	---	--	--

3C.01.03 2 BED	TOTAL AREA Kitchen/Dining Living Master Bedroom Bedroom 2 Internal Area Balcony External Area	77.7 sq m 4.96 x 2.45m 3.65 x 4.58m 3.25 x 4.70m 2.74 x 4.74m 70.2 sq m 4.15 x 1.82m 7.55 sq m	837 sq ft 16'3" x 8'0" 12'0" x 15'0" 10'8" x 15'5" 9'0" x 15'7" 756 sq ft 13'7" x 6'0" 81 sq ft
--------------------------	---	--	---

3C.01.04 1 BED	TOTAL AREA Kitchen Living/Dining Bedroom Internal Area Balcony External Area	55.9 sq m 4.68 x 3.39m 3.73 x 3.72m 3.25 x 4.94m 50.6 sq m 2.95 x 1.82m 5.37 sq m	602 sq ft 15'4" x 11'1" 12'3" x 12'2" 10'8" x 16'2" 544 sq ft 9'8" x 6'0" 58 sq ft
--------------------------	---	--	---

3C.01.05 1 BED	TOTAL AREA Kitchen Living/Dining Bedroom Internal Area Balcony External Area	56.7 sq m 3.79 x 3.10m 3.84 x 3.99m 3.25 x 4.63m 51.4 sq m 2.95 x 1.82m 5.31 sq m	610 sq ft 12'5" x 10'2" 12'7" x 13'1" 10'8" x 15'2" 553 sq ft 9'8" x 5'11" 57 sq ft
--------------------------	---	--	--

3C.01.06 3 BED	TOTAL AREA Kitchen Living/Dining Master Bedroom Bedroom 2 Bedroom 3 Internal Area Balcony External Area	112.8 sq m 4.16 x 3.72m 4.29 x 3.12m 5.09 x 3.12m 5.59 x 2.75m 5.26 x 2.75m 102.5 sq m 1.71 x 6.04m 10.30 sq m	1214 sq ft 13'8" x 12'3" 14'1" x 10'3" 16'8" x 10'3" 18'4" x 9'0" 17'3" x 9'0" 1104 sq ft 5'7" x 19'10" 111 sq ft
--------------------------	--	---	--

3C.01.07 1 BED	TOTAL AREA Kitchen Living/Dining Bedroom Internal Area Balcony External Area	57.2 sq m 3.76 x 3.10m 3.81 x 3.37m 3.26 x 4.95m 51.9 sq m 2.95 x 1.77m 5.24 sq m	615 sq ft 12'4" x 10'2" 12'6" x 11'1" 10'8" x 16'3" 559 sq ft 9'8" x 5'10" 56 sq ft
--------------------------	---	--	--

LEVEL 01



3D.01.01 1 BED	TOTAL AREA Kitchen Living/Dining Bedroom Internal Area Balcony External Area	58.98 sq m 3.73 x 4.25m 3.78 x 2.97m 3.25 x 4.93m 53.1 sq m 3.15 x 1.88m 5.91 x sq m	635 sq ft 12'3" x 13'11" 12'5" x 9'9" 10'8" x 16'2" 571 sq ft 10'4" x 6'2" 64 sq ft
--------------------------	---	---	--

3D.01.02 2 BED	TOTAL AREA Kitchen/Living/Dining Master Bedroom Bedroom 2 Internal Area Balcony External Area	80.50 sq m 4.83 x 5.16m 3.77 x 3.60m 3.44 x 3.23m 73.1 sq m 3.95 x 1.88m 7.41 sq m	867 sq ft 15'10" x 16'11" 12'5" x 11'10" 11'4" x 10'7" 787 sq ft 13'0" x 6'2" 80 sq ft
--------------------------	--	---	---

3D.01.03 1 BED	TOTAL AREA Kitchen Living/Dining Bedroom Internal Area Balcony External Area	56.91 sq m 3.94 x 3.10m 3.99 x 3.79m 3.25 x 4.75m 51 sq m 3.15 x 1.88m 5.91 sq m	613 sq ft 12'11" x 10'2" 13'1" x 12'5" 10'8" x 15'7" 549 sq ft 10'4" x 6'2" 64 sq ft
--------------------------	---	---	---

3D.01.04 1 BED	TOTAL AREA Kitchen Living/Dining Bedroom Internal Area Balcony External Area	57.05 sq m 3.94 x 3.10m 3.99 x 3.80m 3.25 x 4.64m 51 sq m 3.15 x 1.92m 6.05 sq m	614 sq ft 12'11" x 10'2" 13'1" x 12'5" 10'8" x 15'3" 549 sq ft 10'4" x 6'4" 65 sq ft
--------------------------	---	---	---

3D.01.05 1 BED	TOTAL AREA Kitchen Living/Dining Bedroom Internal Area Balcony External Area	64.22 sq m 2.56 x 2.50m 3.81 x 4.19m 3.57 x 5.07m 58.3 sq m 3.15 x 1.88m 5.91 sq m	691 sq ft 8'5" x 8'2" 12'6" x 13'9" 11'9" x 16'7" 628 sq ft 10'4" x 6'2" 64 sq ft
--------------------------	---	---	--

3D.01.06 STUDIO	TOTAL AREA Kitchen Living/Dining Bedroom Internal Area Balcony External Area	51.51 sq m 3.40 x 1.84m 2.54 x 5.58m 2.50 x 4.86m 45.6 sq m 3.15 x 1.88m 5.91 sq m	554 sq ft 11'2" x 6'0" 8'4" x 18'4" 8'2" x 15'11" 491 sq ft 10'4" x 6'2" 64 sq ft
---------------------------	---	---	--

SITE MAP

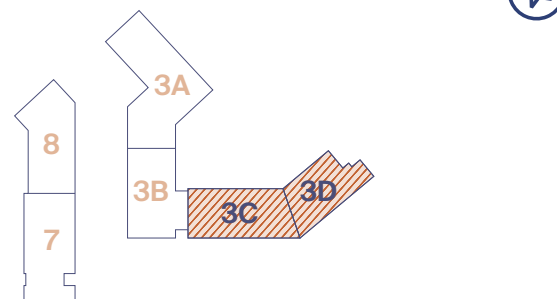

THE ASCENT Level 02



3C.02.01 2 BED	TOTAL AREA Kitchen Living/Dining Master Bedroom Bedroom 2 Internal Area Balcony External Area	94 sq m 4.27 x 3.20m 4.87 x 4.11m 5.69 x 4.42m 3.15 x 6.40m 86.7 sq m 4.15 x 1.78m 7.37 sq m	1012 sq ft 14'0" x 10'6" 16'0" x 13'6" 18'8" x 14'6" 10'4" x 21'0" 933 sq ft 13'7" x 5'10" 79 sq ft
--------------------------	---	--	---

3C.02.02 1 BED	TOTAL AREA Kitchen Living/Dining Bedroom Internal Area Balcony External Area	63.3 sq m 2.35 x 3.00m 3.05 x 7.44m 3.13 x 4.80m 57.9 sq m 2.95 x 1.82m 5.37 sq m	681 sq ft 7'9" x 9'10" 10'0" x 24'5" 10'3" x 15'9" 623 sq ft 9'8" x 6'0" 58 sq ft
--------------------------	---	--	--

3C.02.03 2 BED	TOTAL AREA Kitchen/Dining Living Master Bedroom Bedroom 2 Internal Area Balcony External Area	77.7 sq m 4.96 x 2.45m 3.65 x 4.58m 3.25 x 4.70m 2.74 x 4.74m 70.2 sq m 4.15 x 1.82m 7.55 sq m	837 sq ft 16'3" x 8'0" 12'0" x 15'0" 10'8" x 15'5" 9'0" x 15'7" 756 sq ft 13'7" x 6'0" 81 sq ft
--------------------------	---	--	---

3C.02.04 1 BED	TOTAL AREA Kitchen Living/Dining Bedroom Internal Area Balcony External Area	55.9 sq m 4.68 x 3.39m 3.73 x 3.72m 3.25 x 4.94m 50.6 sq m 2.95 x 1.82m 5.37 sq m	602 sq ft 15'4" x 11'1" 12'3" x 12'2" 10'8" x 16'2" 544 sq ft 9'8" x 6'0" 58 sq ft
--------------------------	---	--	---

3C.02.05 1 BED	TOTAL AREA Kitchen Living/Dining Bedroom Internal Area Balcony External Area	56.7 sq m 3.79 x 3.10m 3.84 x 3.99m 3.25 x 4.63m 51.4 sq m 2.95 x 1.82m 5.31 sq m	610 sq ft 12'5" x 10'2" 12'7" x 13'1" 10'8" x 15'2" 553 sq ft 9'8" x 5'11" 57 sq ft
--------------------------	---	--	--

3C.02.06 3 BED	TOTAL AREA Kitchen Living/Dining Master Bedroom Bedroom 2 Bedroom 3 Internal Area Balcony External Area	112.8 sq m 4.16 x 3.72m 4.29 x 3.12m 5.09 x 3.12m 5.59 x 2.75m 5.26 x 2.75m 102.5 sq m 1.71 x 6.04m 10.30 sq m	1214 sq ft 13'8" x 12'3" 14'1" x 10'3" 16'8" x 10'3" 18'4" x 9'0" 17'3" x 9'0" 1104 sq ft 5'7" x 19'10" 111 sq ft
--------------------------	--	---	--

3C.02.07 1 BED	TOTAL AREA Kitchen Living/Dining Bedroom Internal Area Balcony External Area	57.2 sq m 3.76 x 3.10m 3.81 x 3.37m 3.26 x 4.95m 51.9 sq m 2.95 x 1.77m 5.24 sq m	615 sq ft 12'4" x 10'2" 12'6" x 11'1" 10'8" x 16'3" 559 sq ft 9'8" x 5'10" 56 sq ft
--------------------------	---	--	--

3D.02.01 1 BED	TOTAL AREA Kitchen Living/Dining Bedroom Internal Area Balcony External Area	58.98 sq m 3.73 x 4.25m 3.78 x 2.97m 3.25 x 4.93m 53.1 sq m 3.15 x 1.88m 5.91 sq m	635 sq ft 12'3" x 13'11" 12'5" x 9'9" 10'8" x 16'2" 571 sq ft 10'4" x 6'2" 64 sq ft
--------------------------	---	---	--

3D.02.02 2 BED	TOTAL AREA Kitchen/Living/Dining Master Bedroom Bedroom 2 Internal Area Balcony External Area	80.50 sq m 4.83 x 5.16m 3.77 x 3.60m 3.44 x 3.23m 73.1 sq m 3.95 x 1.88m 7.41 sq m	867 sq ft 15'10" x 16'11" 12'5" x 11'10" 11'4" x 10'7" 787 sq ft 13'0" x 6'2" 80 sq ft
--------------------------	--	---	---

3D.02.03 1 BED	TOTAL AREA Kitchen Living/Dining Bedroom Internal Area Balcony External Area	56.91 sq m 3.94 x 3.10m 3.99 x 3.79m 3.25 x 4.75m 51 sq m 3.15 x 1.88m 5.91 sq m	613 sq ft 12'11" x 10'2" 13'1" x 12'5" 10'8" x 15'7" 549 sq ft 10'4" x 6'2" 64 sq ft
--------------------------	---	---	---

3D.02.04 1 BED	TOTAL AREA Kitchen Living/Dining Bedroom Internal Area Balcony External Area	57.05 sq m 3.94 x 3.10m 3.99 x 3.80m 3.25 x 4.64m 51 sq m 3.15 x 1.92m 6.05 sq m	614 sq ft 12'11" x 10'2" 13'1" x 12'5" 10'8" x 15'3" 549 sq ft 10'4" x 6'4" 65 sq ft
--------------------------	---	---	---

3D.02.05 1 BED	TOTAL AREA Kitchen Living/Dining Bedroom Internal Area Balcony External Area	64.22 sq m 2.56 x 2.50m 3.81 x 4.19m 3.57 x 5.07m 58.3 sq m 3.15 x 1.88m 5.91 sq m	691 sq ft 8'5" x 8'2" 12'6" x 13'9" 11'9" x 16'7" 628 sq ft 10'4" x 6'2" 64 sq ft
--------------------------	---	---	--

3D.02.06 STUDIO	TOTAL AREA Kitchen Living/Dining Bedroom Internal Area Balcony External Area	51.51 sq m 3.40 x 1.84m 2.54 x 5.58m 2.50 x 4.86m 45.6 sq m 3.15 x 1.88m 5.91 sq m	554 sq ft 11'2" x 6'0" 8'4" x 18'4" 8'2" x 15'11" 491 sq ft 10'4" x 6'2" 64 sq ft
---------------------------	---	---	--



LEVEL 02

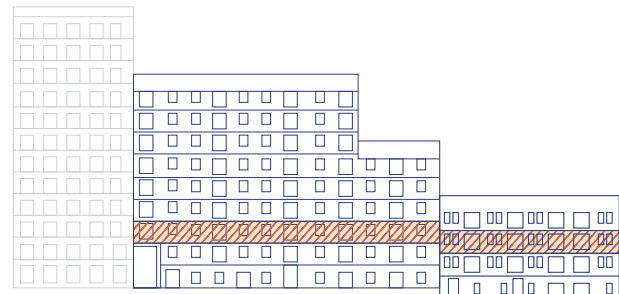

SITE MAP

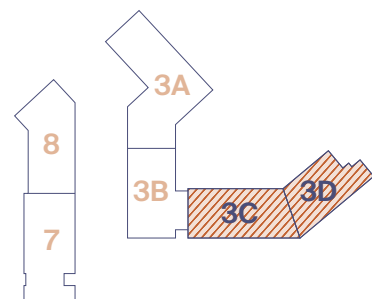

THE ASCENT Level 03



3C.03.01 2 BED	TOTAL AREA Kitchen Living/Dining Master Bedroom Bedroom 2 Internal Area Balcony External Area	94 sq m 4.27 x 3.20m 4.87 x 4.11m 5.69 x 4.42m 3.15 x 6.40m 86.7 sq m 4.15 x 1.78m 7.37 sq m	1012 sq ft 14'0" x 10'6" 16'0" x 13'6" 18'8" x 14'6" 10'4" x 21'0" 933 sq ft 13'7" x 5'10" 79 sq ft
--------------------------	---	--	---

3C.03.02 1 BED	TOTAL AREA Kitchen Living/Dining Bedroom Internal Area Balcony External Area	63.3 sq m 2.35 x 3.00m 3.05 x 7.44m 3.13 x 4.80m 57.9 sq m 2.95 x 1.82m 5.37 sq m	681 sq ft 7'9" x 9'10" 10'0" x 24'5" 10'3" x 15'9" 623 sq ft 9'8" x 6'0" 58 sq ft
--------------------------	---	--	--

3C.03.03 2 BED	TOTAL AREA Kitchen/Dining Living Master Bedroom Bedroom 2 Internal Area Balcony External Area	77.7 sq m 4.96 x 2.45m 3.65 x 4.58m 3.25 x 4.70m 2.74 x 4.74m 70.2 sq m 4.15 x 1.82m 7.55 sq m	837 sq ft 16'3" x 8'0" 12'0" x 15'0" 10'8" x 15'5" 9'0" x 15'7" 756 sq ft 13'7" x 6'0" 81 sq ft
--------------------------	---	--	---

3C.03.04 1 BED	TOTAL AREA Kitchen Living/Dining Bedroom Internal Area Balcony External Area	55.9 sq m 4.68 x 3.39m 3.73 x 3.72m 3.25 x 4.94m 50.6 sq m 2.95 x 1.82m 5.37 sq m	602 sq ft 15'4" x 11'1" 12'3" x 12'2" 10'8" x 16'2" 544 sq ft 9'8" x 6'0" 58 sq ft
--------------------------	---	--	---

3C.03.05 1 BED	TOTAL AREA Kitchen Living/Dining Bedroom Internal Area Balcony External Area	56.7 sq m 3.79 x 3.10m 3.84 x 3.99m 3.25 x 4.63m 51.4 sq m 2.95 x 1.80m 5.31 sq m	610 sq ft 12'5" x 10'2" 12'7" x 13'1" 10'8" x 15'2" 553 sq ft 9'8" x 5'11" 57 sq ft
--------------------------	---	--	--

3C.03.06 3 BED	TOTAL AREA Kitchen Living/Dining Master Bedroom Bedroom 2 Bedroom 3 Internal Area Balcony External Area	112.8 sq m 4.16 x 3.72m 4.29 x 3.12m 5.09 x 3.12m 5.59 x 2.75m 5.26 x 2.75m 102.5 sq m 1.71 x 6.04m 10.30 sq m	1214 sq ft 13'8" x 12'3" 14'1" x 10'3" 16'8" x 10'3" 18'4" x 9'0" 17'3" x 9'0" 1104 sq ft 5'7" x 19'10" 111 sq ft
--------------------------	--	---	--

3C.03.07 1 BED	TOTAL AREA Kitchen Living/Dining Bedroom Internal Area Balcony External Area	57.2 sq m 3.76 x 3.10m 3.81 x 3.37m 3.26 x 4.95m 51.9 sq m 2.95 x 1.77m 5.24 sq m	615 sq ft 12'4" x 10'2" 12'6" x 11'1" 10'8" x 16'3" 559 sq ft 9'8" x 5'10" 56 sq ft
--------------------------	---	--	--

3D.03.01 1 BED	TOTAL AREA Kitchen Living/Dining Bedroom Internal Area Balcony External Area	58.98 sq m 3.73 x 4.25m 3.78 x 2.97m 3.25 x 4.93m 53.1 sq m 3.15 x 1.88m 5.91 sq m	635 sq ft 12'3" x 13'11" 12'5" x 9'9" 10'8" x 16'2" 571 sq ft 10'4" x 6'2" 64 sq ft
--------------------------	---	---	--

3D.03.02 2 BED	TOTAL AREA Kitchen/Living/Dining Master Bedroom Bedroom 2 Internal Area Balcony External Area	80.51 sq m 4.83 x 5.16m 3.77 x 3.60m 3.44 x 3.23m 73.1 sq m 3.95 x 1.88m 7.41 sq m	867 sq ft 15'10" x 16'11" 12'5" x 11'10" 11'4" x 10'7" 787 sq ft 13'0" x 6'2" 80 sq ft
--------------------------	--	---	---

3D.03.03 1 BED	TOTAL AREA Kitchen Living/Dining Bedroom Internal Area Balcony External Area	56.91 sq m 3.94 x 3.10m 3.99 x 3.79m 3.25 x 4.75m 51 sq m 3.15 x 1.88m 5.91 sq m	613 sq ft 12'11" x 10'2" 13'1" x 12'5" 10'8" x 15'7" 549 sq ft 10'4" x 6'2" 64 sq ft
--------------------------	---	---	---

3D.03.04 1 BED	TOTAL AREA Kitchen Living/Dining Bedroom Internal Area Balcony External Area	57.1 sq m 3.94 x 3.10m 3.99 x 3.80m 3.25 x 4.64m 51 sq m 3.15 x 1.92m 6.05 sq m	614 sq ft 12'11" x 10'2" 13'1" x 12'5" 10'8" x 15'3" 549 sq ft 10'4" x 6'4" 65 sq ft
--------------------------	---	--	---

3D.03.05 1 BED	TOTAL AREA Kitchen Living/Dining Bedroom Internal Area Balcony External Area	64.2 sq m 2.55 x 2.50m 3.81 x 4.19m 3.57 x 5.07m 58.3 sq m 3.15 x 1.88m 5.91 sq m	691 sq ft 8'5" x 8'2" 12'6" x 13'9" 11'9" x 16'7" 628 sq ft 10'4" x 6'2" 64 sq ft
--------------------------	---	--	--

3D.03.06 STUDIO	TOTAL AREA Kitchen Living/Dining Bedroom Internal Area Balcony External Area	51.51 sq m 3.40 x 1.84m 2.54 x 5.58m 2.50 x 4.86m 45.6 sq m 3.15 x 1.88m 5.91 sq m	554 sq ft 11'2" x 6'0" 8'4" x 18'4" 8'2" x 15'11" 491 sq ft 10'4" x 6'2" 64 sq ft
---------------------------	---	---	--



LEVEL 03

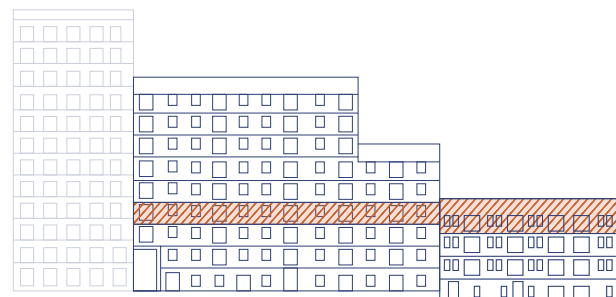

SITE MAP

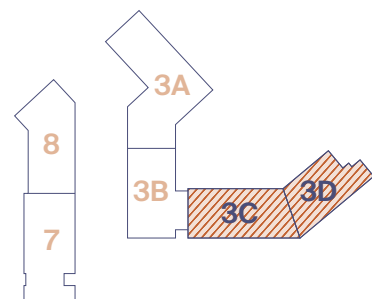

THE ASCENT Level 04



3C.04.01 2 BED	TOTAL AREA	93.7 sq m	1009 sq ft
	Kitchen	2.70 x 2.45m	8'10" x 8'0"
	Living/Dining	4.60 x 4.86m	15'1" x 15'11"
	Master Bedroom	3.15 x 6.40m	10'4" x 21'0"
	Bedroom 2	5.95 x 3.12m	19'6" x 10'3"
	Internal Area	86.7 sq m	933 sq ft
	Balcony	4.15 x 1.71m	13'7" x 5'7"
	External Area	7.08 sq m	76 sq ft

3C.04.05 1 BED	TOTAL AREA	56.7 sq m	610 sq ft
	Kitchen	3.79 x 3.10m	12'5" x 10'2"
	Living/Dining	3.84 x 3.99m	12'7" x 13'1"
	Bedroom	3.25 x 4.63m	10'8" x 15'2"
	Internal Area	51.4 sq m	553 sq ft
	Balcony	2.95 x 1.80m	9'8" x 5'11"
	External Area	5.31 sq m	57 sq ft

3C.04.02 1 BED	TOTAL AREA	63.3 sq m	681 sq ft
	Kitchen	2.35 x 3.00m	7'9" x 9'10"
	Living/Dining	3.05 x 7.44m	10'0" x 24'5"
	Bedroom	3.13 x 4.80m	10'3" x 15'9"
	Internal Area	57.9 sq m	623 sq ft
	Balcony	2.95 x 1.82m	9'8" x 6'0"
	External Area	5.37 sq m	58 sq ft

3C.04.06 2 BED	TOTAL AREA	94.6 sq m	1018 sq ft
	Kitchen/Dining	4.04 x 3.77m	13'3" x 12'5"
	Living	5.20 x 3.12m	17'1" x 10'3"
	Master Bedroom	7.34 x 3.48m	24'1" x 11'5"
	Bedroom 2	4.61 x 2.75m	15'1" x 9'0"
	Internal Area	84.3 sq m	907 sq ft
	Balcony	1.70 x 6.03m	5'7" x 19'10"
	External Area	10.30 sq m	111 sq ft

3C.04.03 2 BED	TOTAL AREA	77.7 sq m	837 sq ft
	Kitchen/Dining	4.96 x 2.45m	16'3" x 8'0"
	Living	3.65 x 4.58m	12'0" x 15'0"
	Master Bedroom	3.25 x 4.70m	10'8" x 15'5"
	Bedroom 2	2.74 x 4.74m	9'0" x 15'7"
	Internal Area	70.2 sq m	756 sq ft
	Balcony	4.15 x 1.82m	13'7" x 6'0"
	External Area	7.55 sq m	81 sq ft

3C.04.07 1 BED	TOTAL AREA	57.17 sq m	615 sq ft
	Kitchen	3.76 x 3.10m	12'4" x 10'2"
	Living/Dining	3.81 x 3.37m	12'6" x 11'1"
	Bedroom	3.26 x 4.95m	10'8" x 16'3"
	Internal Area	51.9 sq m	559 sq ft
	Balcony	2.95 x 1.77m	9'8" x 5'10"
	External Area	5.24 sq m	56 sq ft

3C.04.04 1 BED	TOTAL AREA	55.9 sq m	602 sq ft
	Kitchen	4.68 x 3.39m	15'4" x 11'1"
	Living/Dining	3.73 x 3.72m	12'3" x 12'2"
	Bedroom	3.25 x 4.94m	10'8" x 16'2"
	Internal Area	50.6 sq m	544 sq ft
	Balcony	2.95 x 1.82m	9'8" x 6'0"
	External Area	5.37 sq m	58 sq ft



LEVEL 04

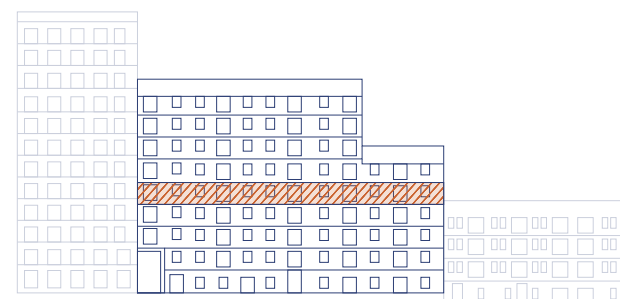

SITE MAP

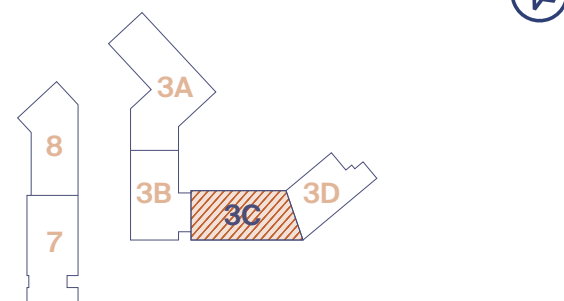

THE ASCENT Level 05



3C.05.01 2 BED	TOTAL AREA	94 sq m	1012 sq ft
	Kitchen	4.27 x 3.20m	14'0" x 10'6"
	Living/Dining	4.87 x 4.11m	16'0" x 13'6"
	Master Bedroom	5.69 x 4.42m	18'8" x 14'6"
	Bedroom 2	3.15 x 6.40m	10'4" x 21'0"
	Internal Area	86.7 sq m	933 sq ft
	Balcony	4.15 x 1.78m	13'7" x 5'10"
	External Area	7.37 sq m	79 sq ft

3C.05.05 1 BED	TOTAL AREA	56.7 sq m	610 sq ft
	Kitchen	3.79 x 3.10m	12'5" x 10'2"
	Living/Dining	3.84 x 3.99m	12'7" x 13'1"
	Bedroom	3.25 x 4.63m	10'8" x 15'2"
	Internal Area	51.4 sq m	553 sq ft
	Balcony	2.95 x 1.80m	9'8" x 5'11"
	External Area	5.31 sq m	57 sq ft

3C.05.02 1 BED	TOTAL AREA	63.3 sq m	681 sq ft
	Kitchen	2.35 x 3.00m	7'9" x 9'10"
	Living/Dining	3.05 x 7.44m	10'0" x 24'5"
	Bedroom	3.13 x 4.80m	10'3" x 15'9"
	Internal Area	57.9 sq m	623 sq ft
	Balcony	2.95 x 1.82m	9'8" x 6'0"
	External Area	5.37 sq m	58 sq ft

3C.05.06 2 BED	TOTAL AREA	94.6 sq m	1018 sq ft
	Kitchen/Dining	4.04 x 3.77m	13'3" x 12'5"
	Living	5.20 x 3.12m	17'1" x 10'3"
	Master Bedroom	7.34 x 3.48m	24'1" x 11'5"
	Bedroom 2	4.61 x 2.75m	15'1" x 9'0"
	Internal Area	84.3 sq m	907 sq ft
	Balcony	1.70 x 6.03m	5'7" x 19'10"
	External Area	10.30 sq m	111 sq ft

3C.05.03 2 BED	TOTAL AREA	77.7 sq m	837 sq ft
	Kitchen/Dining	4.96 x 2.45m	16'3" x 8'0"
	Living	3.64 x 4.58m	12'0" x 15'0"
	Master Bedroom	3.25 x 4.70m	10'8" x 15'5"
	Bedroom 2	2.74 x 4.74m	9'0" x 15'7"
	Internal Area	70.2 sq m	756 sq ft
	Balcony	4.15 x 1.82m	13'7" x 6'0"
	External Area	7.55 sq m	81 sq ft

3C.05.07 1 BED	TOTAL AREA	57.2 sq m	615 sq ft
	Kitchen	3.76 x 3.10m	12'4" x 10'2"
	Living/Dining	3.82 x 3.37m	12'6" x 11'1"
	Bedroom	3.26 x 4.95m	10'8" x 16'3"
	Internal Area	51.9 sq m	559 sq ft
	Balcony	2.95 x 1.78m	9'8" x 5'10"
	External Area	5.24 sq m	56 sq ft

3C.05.04 1 BED	TOTAL AREA	55.9 sq m	602 sq ft
	Kitchen	4.68 x 3.39m	15'4" x 11'1"
	Living/Dining	3.73 x 3.72m	12'3" x 12'2"
	Bedroom	3.25 x 4.94m	10'8" x 16'2"
	Internal Area	50.6 sq m	544 sq ft
	Balcony	2.95 x 1.82m	9'8" x 6'0"
	External Area	5.37 sq m	58 sq ft



LEVEL 05

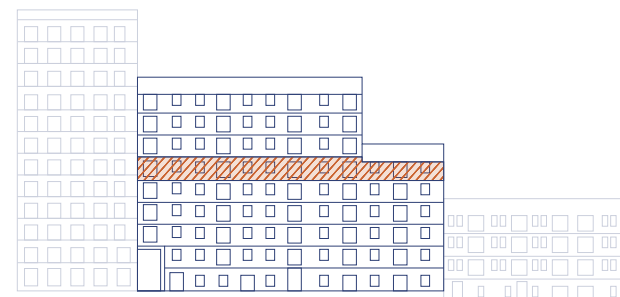

SITE MAP

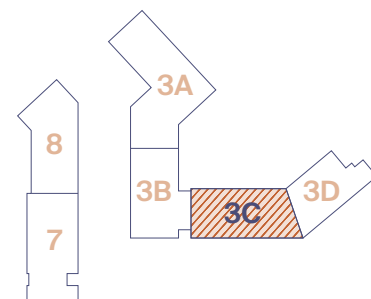

THE ASCENT Level 06



3C.06.01 STUDIO	TOTAL AREA	876 sq m	943 sq ft
	Kitchen/Dining	2.83 x 5.13m	9'3" x 16'10"
	Living	2.87 x 3.92m	9'5" x 12'10"
	Bedroom	5.11 x 4.11m	16'9" x 13'6"
	Internal Area	48.3 sq m	520 sq ft
	Balcony	2.95 x 1.71m	9'8" x 5'7"
	Terrace	5.92 x 5.78m	19'5" x 19'0"
	External Area	39.26 sq m	423 sq ft

3C.06.04 1 BED	TOTAL AREA	56.67 sq m	610 sq ft
	Kitchen	3.79 x 3.10m	12'5" x 10'2"
	Living/Dining	3.84 x 3.99m	12'7" x 13'1"
	Bedroom	3.25 x 4.63m	10'8" x 15'2"
	Internal Area	51.4 sq m	553 sq ft
	Balcony	2.95 x 1.80m	9'8" x 5'11"
	External Area	5.31 sq m	57 sq ft

3C.06.02 STUDIO	TOTAL AREA	104.1 sq m	1121 sq ft
	Kitchen/Living/Dining	3.40 x 4.84m	11'2" x 15'11"
	Bedroom	2.50 x 4.24m	8'3" x 13'11"
	Internal Area	42.9 sq m	462 sq ft
	Balcony	2.95 x 1.78m	9'8" x 5'10"
	Terrace	5.92 x 9.45m	19'5" x 31'0"
	External Area	61.21 sq m	659 sq ft

3C.06.05 2 BED	TOTAL AREA	94.6 sq m	1018 sq ft
	Kitchen/Dining	4.04 x 3.77m	13'3" x 12'5"
	Living	5.20 x 3.12m	17'1" x 10'3"
	Master Bedroom	7.34 x 3.48m	24'1" x 11'5"
	Bedroom 2	4.61 x 2.75m	15'1" x 9'0"
	Internal Area	84.3 sq m	907 sq ft
	Balcony	1.70 x 6.03m	5'7" x 19'10"
	External Area	10.30 sq m	111 sq ft

3C.06.03 1 BED	TOTAL AREA	55.94 sq m	602 sq ft
	Kitchen	4.68 x 3.39m	15'4" x 11'1"
	Living/Dining	3.73 x 3.72m	12'3" x 12'2"
	Bedroom	3.25 x 4.94m	10'8" x 16'2"
	Internal Area	50.6 sq m	544 sq ft
	Balcony	2.95 x 1.82m	9'8" x 6'0"
	External Area	5.37 sq m	58 sq ft

3C.06.06 1 BED	TOTAL AREA	57.2 sq m	615 sq ft
	Kitchen	3.76 x 3.10m	12'4" x 10'2"
	Living/Dining	3.81 x 3.37m	12'6" x 11'1"
	Bedroom	3.26 x 4.95m	10'8" x 16'3"
	Internal Area	51.9 sq m	559 sq ft
	Balcony	2.95 x 1.77m	9'8" x 5'10"
	External Area	5.24 sq m	56 sq ft



LEVEL 06

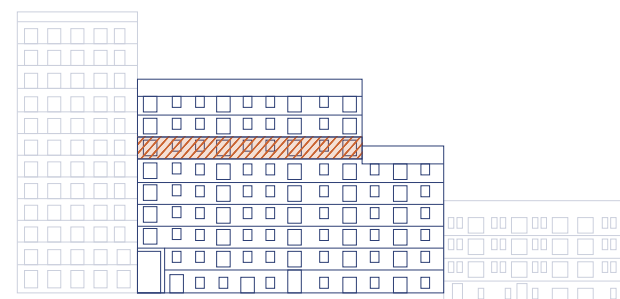

SITE MAP

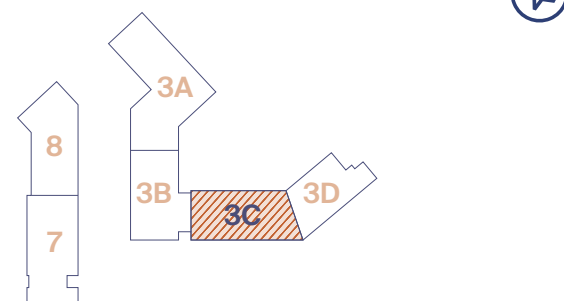

THE ASCENT Level 07



3C.07.01
STUDIO

TOTAL AREA	53.3 sq m	574 sq ft
Kitchen/Dining	2.83 x 5.13m	9'3" x 16'10"
Living	2.87 x 3.92m	9'5" x 12'10"
Bedroom	5.11 x 4.11m	16'9" x 13'6"
Internal Area	48.3 sq m	520 sq ft
Balcony	2.95 x 1.71m	9'8" x 5'7"
External Area	5.04 sq m	54 sq ft

3C.07.04
1 BED

TOTAL AREA	56.67 sq m	610 sq ft
Kitchen	3.79 x 3.10m	12'5" x 10'2"
Living/Dining	3.84 x 3.99m	12'7" x 13'1"
Bedroom	3.25 x 4.63m	10'8" x 15'2"
Internal Area	51.4 sq m	553 sq ft
Balcony	2.95 x 1.80m	9'8" x 5'11"
External Area	5.31 sq m	57 sq ft

3C.07.02
STUDIO

TOTAL AREA	48.2 sq m	519 sq ft
Kitchen/Living/Dining	3.40 x 4.84m	11'2" x 15'11"
Bedroom	2.50 x 4.24m	8'3" x 13'11"
Internal Area	42.9 sq m	462 sq ft
Balcony	2.95 x 1.78m	9'8" x 5'10"
External Area	5.24 sq m	56 sq ft

3C.07.05
2 BED

TOTAL AREA	94.6 sq m	1018 sq ft
Kitchen/Dining	4.04 x 3.77m	13'3" x 12'5"
Living	5.20 x 3.12m	17'1" x 10'3"
Master Bedroom	7.34 x 3.48m	24'1" x 11'5"
Bedroom 2	4.61 x 2.75m	15'1" x 9'0"
Internal Area	84.3 sq m	907 sq ft
Balcony	1.70 x 6.03m	5'7" x 19'10"
External Area	10.30 sq m	111 sq ft

3C.07.03
1 BED

TOTAL AREA	55.9 sq m	602 sq ft
Kitchen	4.68 x 3.39m	15'4" x 11'1"
Living/Dining	3.73 x 3.72m	12'3" x 12'2"
Bedroom	3.25 x 4.94m	10'8" x 16'2"
Internal Area	50.6 sq m	544 sq ft
Balcony	2.95 x 1.82m	9'8" x 6'0"
External Area	5.37 sq m	58 sq ft

3C.07.06
1 BED

TOTAL AREA	57.2 sq m	615 sq ft
Kitchen	3.76 x 3.10m	12'4" x 10'2"
Living/Dining	3.81 x 3.37m	12'6" x 11'1"
Bedroom	3.26 x 4.95m	10'8" x 16'3"
Internal Area	51.9 sq m	559 sq ft
Balcony	2.95 x 1.77m	9'8" x 5'10"
External Area	5.24 sq m	56 sq ft



LEVEL 07

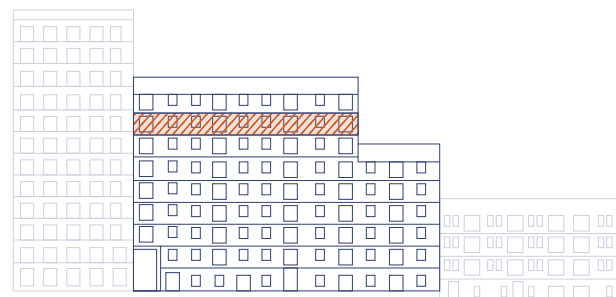

SITE MAP

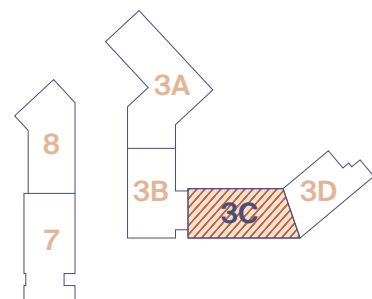

THE ASCENT Level 08



3C.08.01 STUDIO	TOTAL AREA	53.3 sq m	574 sq ft
	Kitchen/Dining	2.83 x 5.13m	9'3" x 16'10"
	Living	2.87 x 3.92m	9'5" x 12'10"
	Bedroom	5.11 x 4.11m	16'9" x 13'6"
	Internal Area	48.3 sq m	520 sq ft
	Balcony	2.95 x 1.71m	9'8" x 5'7"
	External Area	5.04 sq m	54 sq ft

3C.08.04 1 BED	TOTAL AREA	56.67 sq m	610 sq ft
	Kitchen	3.79 x 3.10m	12'5" x 10'2"
	Living/Dining	3.84 x 3.99m	12'7" x 13'1"
	Bedroom	3.25 x 4.63m	10'8" x 15'2"
	Internal Area	51.4 sq m	553 sq ft
	Balcony	2.95 x 1.80m	9'8" x 5'11"
	External Area	5.31 sq m	57 sq ft

3C.08.02 STUDIO	TOTAL AREA	48.2 sq m	519 sq ft
	Kitchen /Living/Dining	3.40 x 4.84m	11'2" x 15'11"
	Bedroom	2.50 x 4.24m	8'3" x 13'11"
	Internal Area	42.9 sq m	462 sq ft
	Balcony	2.95 x 1.78m	9'8" x 5'10"
	External Area	5.24 sq m	56 sq ft

3C.08.05 2 BED	TOTAL AREA	94.6 sq m	1018 sq ft
	Kitchen/Dining	4.04 x 3.77m	13'3" x 12'5"
	Living	5.20 x 3.12m	17'1" x 10'3"
	Master Bedroom	7.34 x 3.48m	24'1" x 11'5"
	Bedroom 2	4.61 x 2.75m	15'1" x 9'0"
	Internal Area	84.3 sq m	907 sq ft
	Balcony	1.70 x 6.03m	5'7" x 19'10"
	External Area	10.30 sq m	111 sq ft

3C.08.03 1 BED	TOTAL AREA	55.9 sq m	602 sq ft
	Kitchen	4.68 x 3.39m	15'4" x 11'1"
	Living/Dining	3.73 x 3.72m	12'3" x 12'2"
	Bedroom	3.25 x 4.94m	10'8" x 16'2"
	Internal Area	50.6 sq m	544 sq ft
	Balcony	2.95 x 1.82m	9'8" x 6'0"
	External Area	5.37 sq m	58 sq ft

3C.08.06 1 BED	TOTAL AREA	57.2 sq m	615 sq ft
	Kitchen	3.76 x 3.10m	12'4" x 10'2"
	Living/Dining	3.81 x 3.37m	12'6" x 11'1"
	Bedroom	3.26 x 4.95m	10'8" x 16'3"
	Internal Area	51.9 sq m	559 sq ft
	Balcony	2.95 x 1.77m	9'8" x 5'10"
	External Area	5.24 sq m	56 sq ft

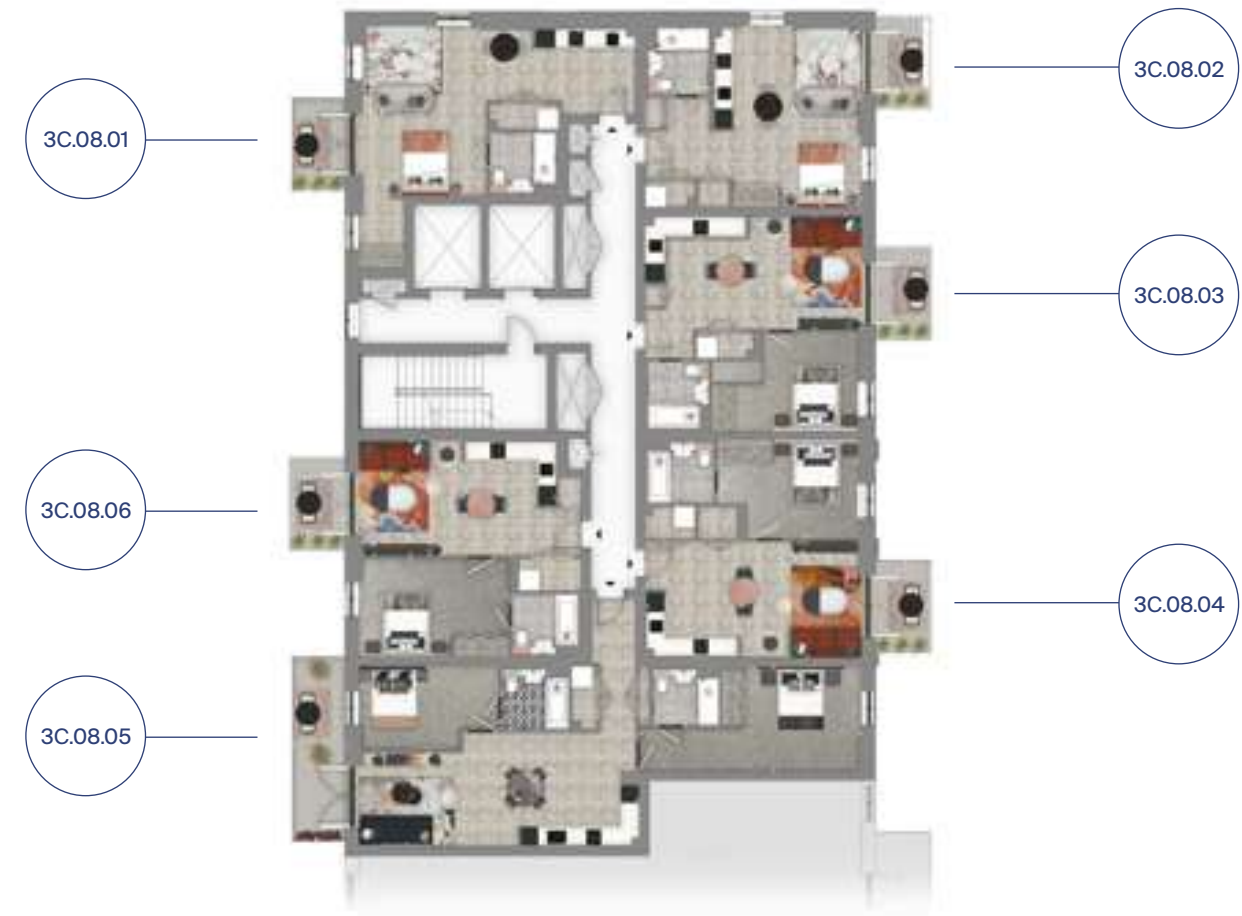

LEVEL 08

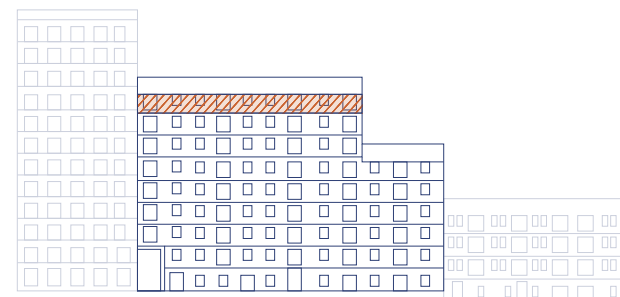

SITE MAP

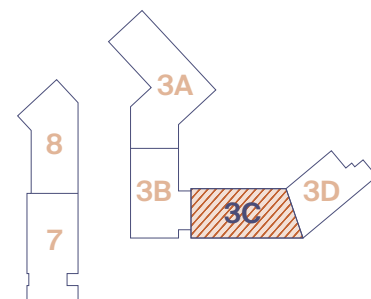

A collaboration between MOUNT ANVIL and PEABODY



↑ THREE WATERS, BOW CREEK E3
Mount Anvil and Peabody's previous partnership

"With Peabody's rich heritage and Mount Anvil's reputation for unparalleled taste and workmanship, One Clapham Junction promises to be a masterpiece of collaboration"

MOUNT ANVIL *Investing in Quality*

90% of our people are also shareholders, so there's more pride poured into every project.

Our approach drives continuous improvement, bringing together some of the best minds in the business to create carefully considered and beautifully built homes that will endure.

This is what quality means to us, exceeding industry standards at every step.

LONDON SPECIALISTS

We've worked here and only here for 30 years - we know our great city and we know how to deliver what our residents care about.

AWARD-WINNING

- RESI Development of the Year
- Building Awards Housebuilder of the Year
- WhatHouse? Best Interior Design

PROJECT DIRECTORS

Mount Anvil's Project Directors have decades of London experience, so delivery of your home is in safe hands.

ARCHITECTURE

In-house architects refine layouts to create exceptional living spaces.

DESIGN PLANNING

Our bespoke 4D software helps deliver projects to a higher standard and with fewer complications.

HEALTH & SAFETY

Mount Anvil is proud to be the British Safety Council highest-rated developer.

FIVE STAR SERVICE

Your personal Customer Experience Manager will be by your side throughout the buying process, from answering your initial questions to showing you around your home.

CUSTOMER CARE

We've got you covered with year-round, 24-hour homeowner care.

PEABODY *More than just a place to live*

Founded in 1862, Peabody is recognised for exceptional quality homes, innovative design and a particular focus on placemaking.

A Peabody building is more than just a place to live. It's a sanctuary, a haven. It's a home.

EXPERTISE

With over 160 years of experience and expertise in property in London, Peabody is relentlessly committed to creating great places and building sustainable, high-quality new homes that stand the test of time.

AWARD-WINNING

- Recognised at some of the biggest awards:
- Evening Standard
 - Sunday Times British Homes Awards
 - What House
 - Royal Institute of British Architects

INVESTING IN COMMUNITIES

With significant development and regeneration expertise, Peabody invests in communities for the long-term and supports people to be healthier, wealthier and happier.

And with Peabody's rich heritage and Mount Anvil's reputation for unparalleled taste and workmanship, One Clapham Junction promises to be a masterpiece of collaboration.

01 These particulars are set out as a general outline only for guidance to intending Purchasers or Lessees, and do not constitute any part of an offer or contract. Any intending Purchasers, Lessees or Third Parties should not rely on them as statements or representations of fact, but must satisfy themselves by inspection, searches, enquiries, surveys or otherwise as to their accuracy. Mount Anvil and Peabody as such cannot be held responsible for any loss or damage including without limitation, indirect or consequential loss or damage, or any loss of profits resulting from direct or indirect actions based upon the content of these particulars.

02 All internal and external images of the development are computer generated images and are indicative only. All images used, including computer generated images and view photography, are for illustrative purposes. Individual features may vary. Furniture shown in images is not included in sales, prospective purchasers should not rely on the information within these particulars and must get their solicitor to check the plans and specification attached to their contract.

03 Floorplates are for illustration of layouts only and are not to scale. Planting on the balconies and terraces are indicative only and does not form part of the standard specification. All measurements given may vary within a tolerance of 5%.

04 The development name 'One Clapham Junction' is for marketing purposes only and Royal Mail may not include this within the determined postal address.

05 It should not be assumed that the property has all necessary planning, building regulation or other consents and Mount Anvil / Peabody have not tested any services, equipment or facilities. Any intending Purchasers, Lessees or Third Parties must satisfy themselves by inspection or otherwise.

06 The VAT position relating to the property may change without notice.

07 Travel times are approximate and calculated via Google Maps and TFL.

08 Mount Anvil and Peabody reserve the right (whether through the planning process or otherwise) to increase the height and/or elevation and/or massing or otherwise (including accommodation) of any block in the development. You'll be regarded, when making a reservation, as being aware and accepting this. This means you'll be expected to accept any consequential change in outlook or amenity because of such changes.

A destination by



Mount Anvil,
better London living



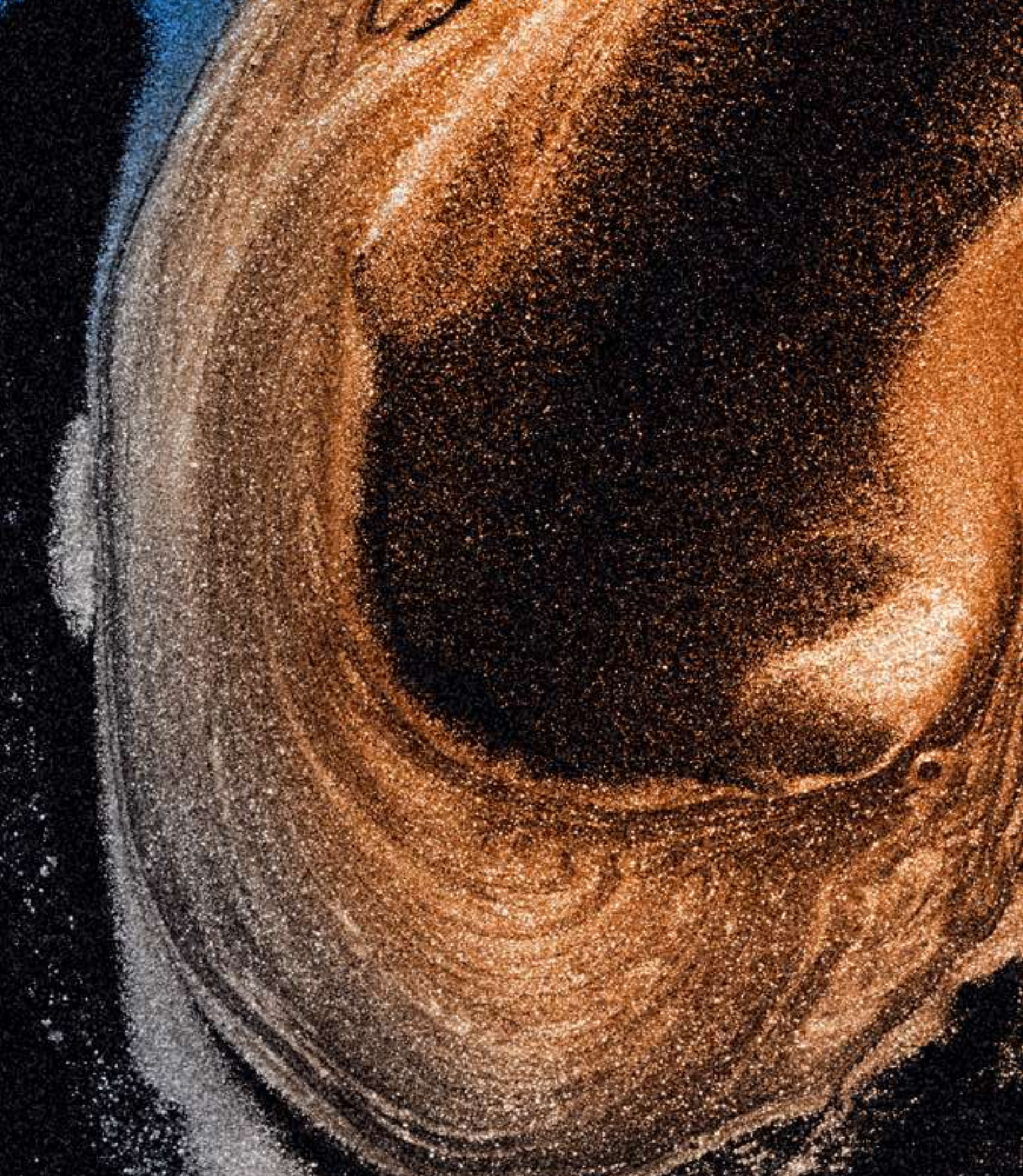

A destination by

 **Mount Anvil,**
better London living

 **Peabody**

ONECLAPHAMJUNCTION.COM